

SE

Strand drying prior to cutting



The SE air knife guarantees efficient strand drying during pelletizing in both compound and masterbatch applications. Filled and reinforced materials require effective strand drying to minimize the residual moisture of the pellets, reduce dust and avoid premature wear of the cutting tools.

Your benefits

- High suction power for low residual moisture values
- Dehumidification of suction air and water recirculation
- Targeted water return via pump
- Low sound emission < 80 dB(A)
- Short delivery times
- Easy start-up (»plug & run«)

SE

Strand drying prior to cutting

Additional benefits of the continual development of the SE family are:

- Effective dehumidification of suction air
- Insensitive to dust and dirt
- Wear protection (optional)

The air knife SE allows very flexible and variable positioning of the suction box. Both height and inclination are adjustable, positioning above or behind the cooling trough.

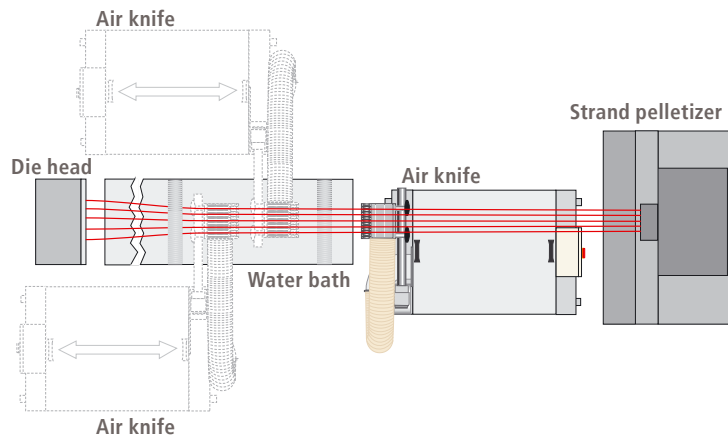

Possibilities to place the air knife

Technical data:	SE100-2	SE200-2	SE400-2	SE600-2	SE900-2
Working width [mm]:	100	200	400	600	900
Number of strands, Ø 3 mm:	25	50	100	150	225
Suction air flow [m³/min]:	10	20	40	60	90
Blower motor power [kW]:	1.1	3	7.5	15	18.5
De-watering:	Gravity	Pump	Pump	Pump	Pump

